

AC GUITARS (ACG) FILTER-BASED EQ-02 SYSTEM

If you are used to the normal cut and boost type of EQ using the ACG pre-amp will require a different approach in order to get the most from it.

First a few notes on the principals behind the design and then a few suggestions on how to get the best from it.

Note: With regard to knob rotation:

ACW = Backing a knob off or turning it anti-clockwise

CW = Turning a knob up towards maximum or turning it clockwise.

Volume/Blend Stack

The volume of the instrument is controlled by the upper ring on the stack while the lower ring controls the mixing of the outputs from the two pickups. Turn ACW for the bridge pickup alone and CW for the neck pickup. Intermediate settings allow a mix of the two pickups. The indented centre click gives an equal mix. In several configurations the volume and blend are on individual pots.

The main elements in the pre-amp are the filter stacks.

Bass Filter Stack

First, a filter lets some parts of the frequency spectrum through and not others. The type of filter determines which part it lets through. Also, the amount of cut-off is important. If it has a sharp or steep cut-off, it is more dramatic.

There is a LOW PASS FILTER where the frequency is variable over quite a broad range; from just allowing the very deepest sounds through, to allowing upper midrange frequencies of 6.3 kHz. As the frequency control is adjusted, sound ranges from very deep to a much more open sound, taking in more midrange as the control is increased. As it's a low pass filter, the very low bass is always there, but the high frequencies can be progressively opened up.

This aspect of the pre-amp is controlled by the lower ring on the filter stack. Fully ACW giving you a very full deep bass sound. As the knob is turned CW, more of the higher frequencies are let through the filter.

The upper knob of the filter stack controls the overshoot peak. This means that some resonance can be added at the frequency of cut-off to which the filter is tuned. This has the effect of making the sound much richer at the point of the filter frequency. So if the filter is set to a low frequency on the neck pickup, and the overshoot peak is increased, you get a massive reggae style of sound as you're giving resonance to the more fundamental frequencies. If the filter is set higher, it accentuates the harmonics. To give you

an idea, if you rotate the filter control up and down when the peak is turned up, it sounds very much like a wah control.

The upper ring on the filter stack sets the peak level. Fully CW is maximum gain (boost) and when turned ACW the gain is reduced.

Treble Filter Stack

The treble stack is there to address the top end of the spectrum as the filters cut off below the very highest frequencies you can get from roundwound strings. Here we're talking about the high end 'sizzle'. The frequency control also goes well down into the upper midrange around 1kHz. This is another filter type, a HIGH PASS FILTER in the treble signal path. This sets the frequency above which the treble spectrum is allowed to pass through.

The upper knob controls the gain (boost) applied to the treble frequency while the lower ring controls the frequencies which are allowed through. Turning the frequency ACW allows more of the lower treble spectrum. Setting more CW allows only the higher frequencies of the treble spectrum to pass.

Passive tone

In the 4 knob J plate version and the 5 knob version there is the addition of a passive tone control. The dual passive tone pot and two capacitors are connected directly to the pickups in order to create a passive roll-off via direct interaction with the pickups.

INTERNAL CONTROLS

The pre-amp also has some internal control options. There is a separate gain control for each pickup input. The main use for this control is to allow you to use two different types of pickup but still have a balanced volume from them both.

In the basses I make I use a Ceramic magnet in the bridge pickup and an Alnico magnet in the neck pickup. Because of the two different magnet types the output from the pickups is slightly different. The Ceramic pickup has a higher output than the Alnico pickup so I boost the gain on the Alnico pickup slightly to balance out the difference.

This would also allow you to use say a Musicman style pickup with a Jazz style pickup and still be able to balance their respective volumes.

The other internal Preset Adjuster is NOT USER ADJUSTABLE and under no circumstances should it be moved. This will void your warranty and ACG will be in

no way responsible for any consequential damaged caused if the user adjusts this pot.

I hope this will point you in the right direction with your new ACG pre-amp. It is only a starting point as I am sure you will soon find there are a fantastic range of sounds available and finding what best suits you and your style of playing may take a little longer due to the flexibility of the pre-amp.

Best regards

Alan

E: sayhello@acguitars.co.uk

W: www.acguitars.co.uk

ACG EQ-02

Pre-amp installation instructions.

Wiring key for the main board.

This board is common to all configurations. Filter stack connection is now duplicated on the reverse of the board.

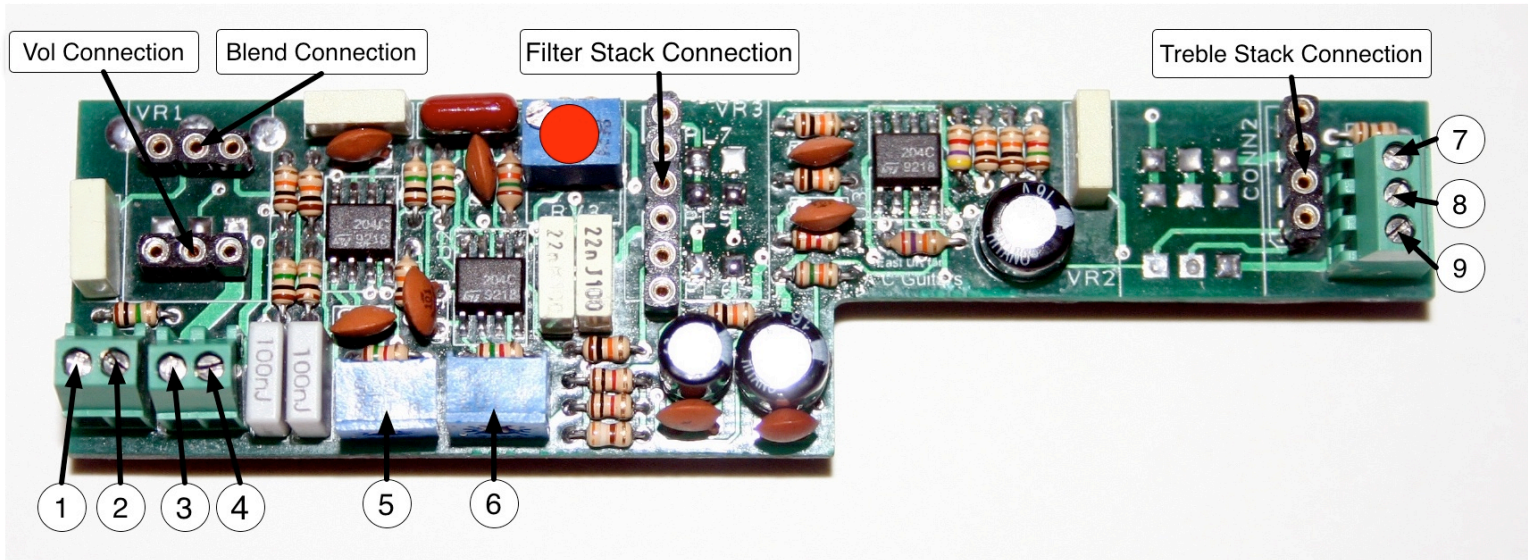

1. Cold (-) input for neck pickup. **Note:** Use this Input for the Single Pickup version
2. Hot (+) input for neck pickup. **Note:** Use this Input for the Single Pickup version
3. Cold (-) input for bridge pickup. (N/A for Single Pickup version)
4. Hot (+) input for bridge pickup. (N/A for Single Pickup version)
5. Gain control for neck pickup.(0-+12dB) **Note:** Use this Gain Control for the Single Pickup version
6. Gain control for bridge pickup. (0-+12dB) (N/A for Single Pickup version)
7. Positive connection for battery clip. (red wire)
8. Output to jack socket. (Orange wire tip on jack socket)
9. Ground (green wire ground on jack socket)

ACG EQ-02

Pre-amp installation instructions.

PASSIVE TONE WIRING

The passive tone is wired directly into the pickup inputs via a 3 wire ribbon cable.

The centre wire is connected in to a Cold input (3) the outer wires are connected to the hot inputs. (2 & 4)

The other internal control (marked in red) is NOT USER ADJUSTABLE and under no circumstances should it be moved. This will void your warranty and ACG will be in no way responsible for any consequential damaged caused if the user adjusts this pot.

CONNECTING THE POTS

- . 3K/S and 4K/S versions have the Volume pot on a triple wire with a plug on the end. Plug this into the Vol Connection, making sure it has the correct orientation, according to the illustration. There should already be a link plug in the Blend Connector. Again make sure its orientation is correct.
- . 3K and 4K/PT versions have the Volume/Blend combined on a small circuit board, with two flat flexi-links attached. Push the flexi marked V into the Vol Connection and B into the Blend Connection.
- . 4K and 5K versions should have their individual Volume (marked V) and Blend (marked B) pots already connected to the circuit board, via their triple wires and plugs. If for any reason they are not connected, insert their plugs into respective sockets, making sure orientation is correct.
- . Note: The flat flexi-strips are designed to be formed and readily bendable, but try to keep this to a minimum without any sharp corners.
- . Important: Make sure all threaded bushes for the pots are solidly grounded via screening or other highly conductive material. (Although conductive paint is fine for screening it should not be used as a method for grounding the pots of the pre-amp)
- . The additional black wire should be attached to the cavity ground.
- . The pre-amp can be powered by 9 or 18 volts.

ACG EQ02 configurations. Pot orientation.

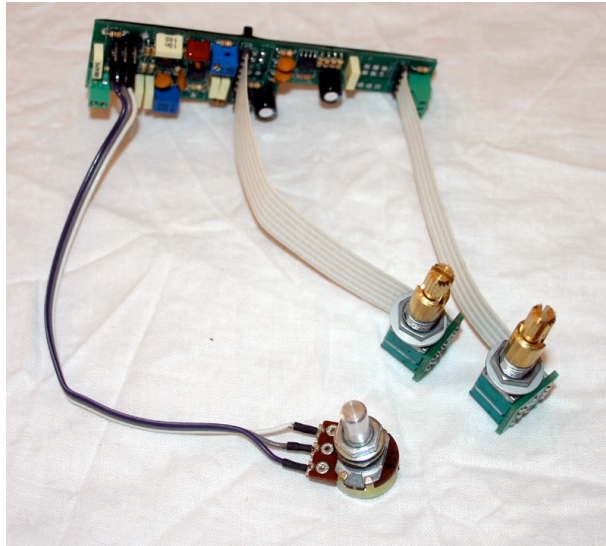

3K/S. 4K/S made with the addition of the Passive Tone.

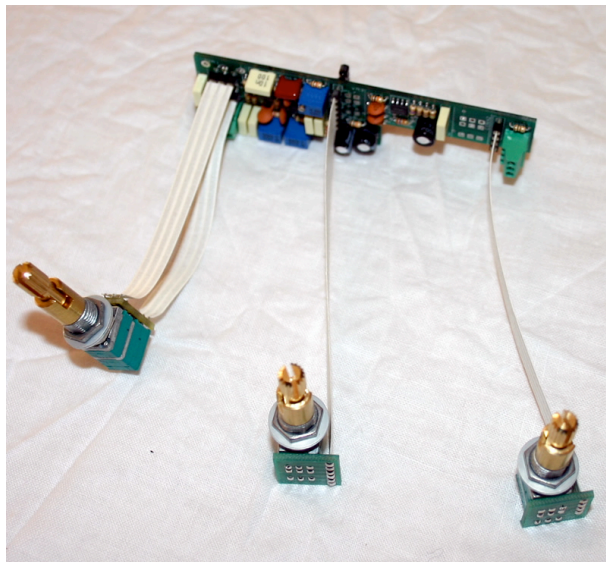

3K. 4K/PT made with the addition of the Passive Tone.

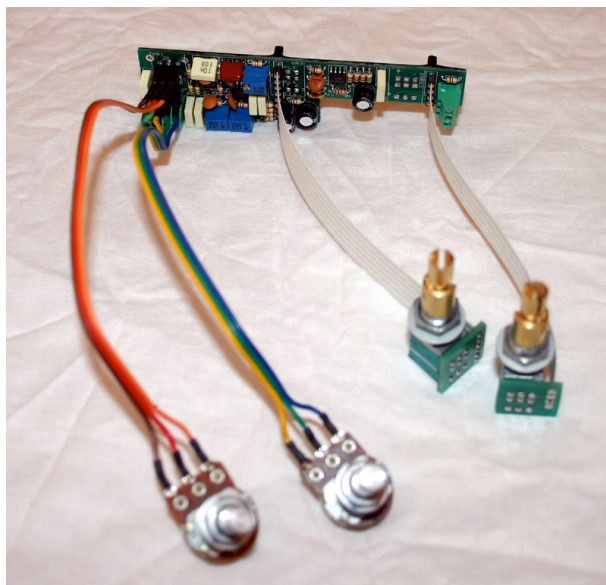

4K. 5K made with addition of Passive Tone.